

AVERTX

HD320

Night Vision HD Indoor/Outdoor IP
Mini Dome Camera

User Manual



HD320: Night Vision HD Indoor/Outdoor IP Dome Camera

Operations Manual

Manual Edition 35156AB – March 2017

©2017, AvertX

All Rights Reserved

No part of this document may be reproduced by any means, electronic or mechanical, for any purpose, except as expressed in the Software License Agreement. AVERTX shall not be liable for technical or editorial errors or omissions contained herein. The information in this document is subject to change without notice.

The information in this publication is provided “as is” without warranty of any kind. The entire risk arising out of the use of this information remains with recipient. In no event shall AVERTX be liable for any direct, consequential, incidental, special, punitive, or other damages whatsoever (including without limitation, damages for loss of business profits, business interruption or loss of business information), even if AVERTX has been advised of the possibility of such damages or whether in an action, contract or tort, including negligence.

This software and documentation are copyrighted. All other rights, including ownership of the software, are reserved to AvertX. AVERTX, and AvertX, are registered trademarks of AVERTX in the United States and elsewhere; Windows is a registered trademarks of Microsoft Corporation. All other brand and product names are trademarks or registered trademarks of the respective owners.

The following words and symbols mark special messages throughout this guide:

WARNING: Text set off in this manner indicates that failure to follow directions could result in bodily harm or loss of life.

CAUTION: Text set off in this manner indicates that failure to follow directions could result in damage to equipment or loss of information.

AVERTX

IMPORTANT SAFEGUARDS

1. Read Instructions

Read all of the safety and operating instructions before using the product.

2. Retain Instructions

Save these instructions for future reference.

3. Attachments / Accessories

Do not use attachments or accessories unless recommended by the appliance manufacturer as they may cause hazards, damage product and void warranty.

4. Installation

Do not place or mount this product in or on an unstable or improperly supported location. Improperly installed product may fall, causing serious injury to a child or adult, and damage to the product. Use only with a mounting device recommended by the manufacturer, or sold with the product. To insure proper mounting, follow the manufacturer's instructions and use only mounting accessories recommended by manufacturer.

5. Power source

This product should be operated only from the type of power source indicated on the marking label.

35217AB

Precautions

Operating

- Before using, make sure power supply and others are properly connected.
- While operating, if any abnormal condition or malfunction is observed, stop using the camera immediately and then contact AvertX Customer Support.

Handling

- Do not disassemble or tamper with parts inside the camera.
- Do not drop or subject the camera to shock and vibration as this can damage camera.
- Care must be taken when you clean the clear lens cover. Scratches and dust will ruin the image quality of your camera. Do not use strong or abrasive detergents when cleaning the camera body. Use a dry cloth to clean the camera when it is dirty. In case the dirt is hard to remove, use a mild detergent and wipe the camera gently.

Installation and Storage

- Do not install the camera in areas of extreme temperatures in excess of the allowable range. (-35°F~ 122°F / -37°C ~ 50°C)
- Avoid installing in humid or dusty places. The relative humidity must be below 90%.
- Avoid installing in places where radiation is present.
- Avoid installing in places where there are strong magnetic fields and electric signals.
- Avoid installing in places where the camera would be subject to strong vibrations.
- Never face the camera toward the sun. Do not aim at bright objects. Whether the camera is in use or not, never aim it at the sun or other extremely bright objects. Otherwise the camera may be damaged.

REGULATION

This device complies with Part 15 of the FCC Rules. Operation is subject to the following two conditions: (1) this device may not cause harmful interference, and (2) this device must accept any interference received, including interference that may cause undesired operation.

This symbol on the product or on its packaging indicates that this product shall not be treated as household waste in accordance with Directive 2002/96/EC. Instead it shall be handed over to the applicable collection point for the recycling of electrical and electronic equipment. By proper waste handling of this product you ensure that it has no negative consequences for the environment and human health, which could otherwise be caused if this product is thrown into the garbage bin. The recycling of materials will help to conserve natural resources.

For more details information about recycling of this product, please contact your local city office, your household waste disposal service or the shop where you purchased the product.

Compliance is evidenced by written declaration from our suppliers, assuring that any potential trace contamination levels of restricted substances are below the maximum level set by EU Directive 2002/95/EC, or are exempted due to their application.

WARNING

DANGEROUS HIGH VOLTAGES ARE PRESENT INSIDE THE ENCLOSURE.

REFER SERVICING TO QUALIFIED PERSONNEL ONLY.

CAUTION



TABLE OF CONTENTS

TABLE OF CONTENTS.....	5
INTRODUCTION.....	9
Overview	9
Camera Default Settings	9
Product Features.....	9
ONE: GETTING STARTED	10
Box Contents.....	10
Camera Overview.....	10
Camera Diagram	10
Dimensions.....	11
Connections	11
Weather Resistant Cable Connector.....	12
TWO: CONNECTING.....	13
Bench test	13
AvertX Camera Finder.....	13
Finding IP Cameras.....	13
Accessing the Camera	13
Changing the IP Address	13
THREE: SETUP AND CONFIGURATION	14
Installing the camera	14
Ceiling and Wall Installation	14
Tilt and Rotation Adjustment	15
Consideration for Wall Installations	15
Considerations for Infrared (IR) Lights	16

MicroSD Card.....	16
Focusing the Camera Lens	16
Cleaning the Dome.....	16
To clean the dome:.....	16
Connecting to the Camera.....	17
Connecting in a Web Browser	17
Default Username and Password.....	17
Administrator/User Privileges	17
Connecting a Stream.....	17
Preparation	17
Logging Into the Web Interface.....	18
Introduction to the Web Interface.....	18
Initial Configuration	18
FOUR: CONFIGURING SETTINGS.....	20
Network Configuration	20
TCP/IP	20
IPv4.....	20
Port.....	21
DDNS	22
FTP	22
E-Mail	23
Port Mapping.....	23
Video Configuration	24
Video Configuration	24
Configuring Capture	24
Image Configuration	25
Image Enhancement	25
Exposure	26

Smart Illumination.....	28
White Balance	28
Defog.....	29
OSD Settings.....	30
Privacy Mask.....	31
Alarm Configuration.....	32
Configuring Motion Detection Alarm.....	32
Configuring Tampering Alarm.....	34
Memory Card Storage	35
Manual storage.....	35
Downloading recorded video from SD Card	36
Record Download.....	36
Security	37
User Management.....	37
Setting Secure Data Transmission	37
HTTPS	37
APR Binding.....	38
Hide Vendor Information.....	38
Video Watermark.....	38
System	38
Setting the System Time	38
Viewing Device Status.....	39
Upgrading the Device.....	39
Restarting the System	40
Importing and Exporting System Configuration File	40
FIVE: LIVE VIEW.....	41
Live View Toolbar	41
APPENDIX A GLOSSARY	42

APPENDIX B FAQ..... 43

APPENDIX C: SPECIFICATIONS 44

 Camera Specifications..... 44

INTRODUCTION

OVERVIEW

The HD320 is a high power, rugged outdoor IP dome camera. This camera comes equipped with a 4MP 3.6mm lens that provides crisp and clear images.

The HD320 also features Spectrum Vision WDR and True Day/Night for improved low light performance, and adaptive (smart) IR technology to prevent overexposure of objects close to the camera.

This camera holds an IP66 rating and is functional down to -35°F making it a perfect camera for extreme weather installations. In addition, this camera has an IK10 vandal rating and it can be fully powered over PoE, eliminating the need for additional cabling and giving you peace of mind in any installation location.

Camera Default Settings

IP Address	192.168.0.250
Username	admin
Password	1234
Management Port	80
Streaming Port (RTSP)	554





Product Features

- Progressive Scan CMOS Sensor
- 4MP Resolution
- Integrated Heater
- H.264 Encoding
- Dual Streaming
- Multi-Language Support
- Tampering Alarm
- Spectrum Vision Wide Dynamic Range (WDR)
- Motion Detection
- Privacy Masks
- Smart Picture Quality / 3D Noise Reduction
- Network Failure Detection
- True Day/Night (ICR)
- IR LED Module (working distance up to 100')
- Weatherproof (IP66 Outdoor Rated)
- ONVIF Support

ONE: GETTING STARTED

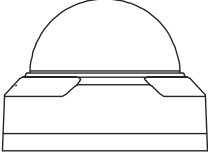
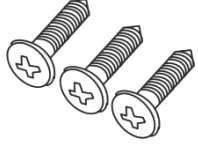
BOX CONTENTS

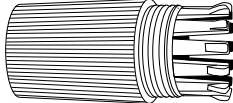
Before proceeding, please check that the box contains the items listed here. If any item is missing or has defects, DO NOT install or operate the product and contact your dealer for assistance.

 <p>HD320 Camera</p>	 <p>Self Tapping Mounting Screws</p>	 <p>Plastic Anchors (includes extra)</p>
 <p>Quick Start Guide</p>	 <p>IP66 Cable Connector</p>	 <p>Security Torx Tool</p>

CAMERA OVERVIEW

Before installing or connecting the Dome camera, please refer to this section and complete preparations for camera setup and all switch settings.

Camera Diagram

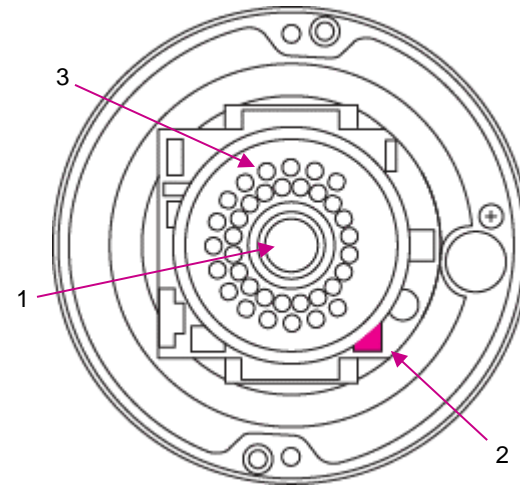

1	Lens	To adjust angle, see Tilt and Rotation Adjustment .
2	MicroSD Slot	Insert MicroSD card for backup recording
3	IR Lights	Holds IR LED lights and light sensor.

Dimensions

Diameter – 4.28" (108.5 mm)

Height – 3.2" (81 mm)

Side View:

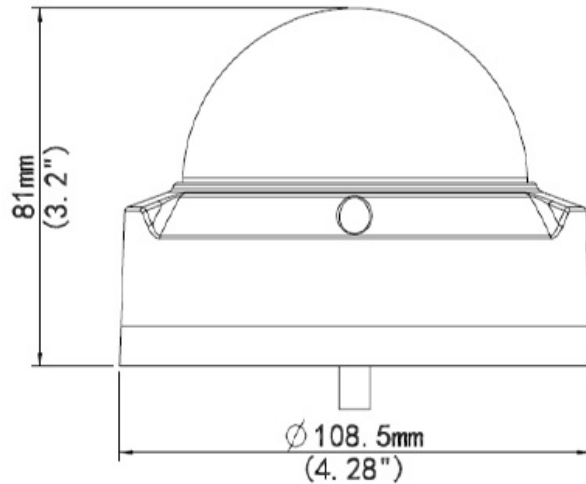

Bottom View:

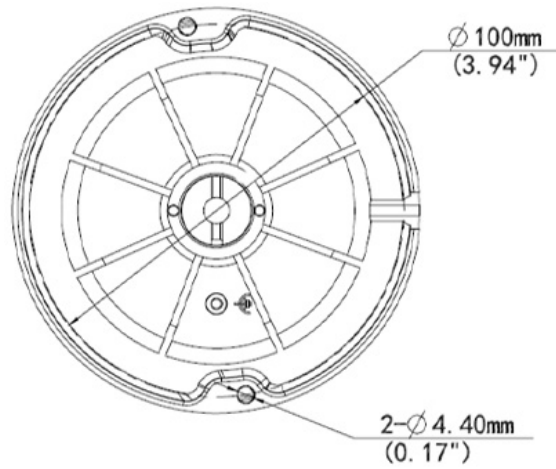

Connections

The HD320 cameras use Power over Ethernet (PoE). The only connection on the camera is the RJ45 Ethernet dongle located on the rear of the camera. Connect one end of the Ethernet cable to the dongle, and connect the other end to the recorder, or to a PoE switch.

- Protect the network cable connection from water damage by running the cord inside a wall or ceiling, or through conduit.
- If passing the cord through a wall or ceiling, drill a 3/4" hole.
- For outdoor installations, seal any holes in the wall or ceiling with silicone caulk to protect against water intrusion.

AvertX recommends using Category 5 Ethernet cable to connect the camera to your network. For the best transmission quality, the cable length should not exceed 328 feet (100 meters).

Weather Resistant Cable Connector

This camera features an IP66-rated weather resistant connector. For unprotected outdoor connections, screw the connector on the included Ethernet camera cable onto the camera dongle. If your installation location does not require a water resistant connection, loosen and slide the connector back on the cable until it's out of the way.

This camera features an IP66-rated waterproof cable connector for unprotected outdoor connections. **You do not need to re-terminate the cable to use the waterproof cable connector.**

Included Pieces:

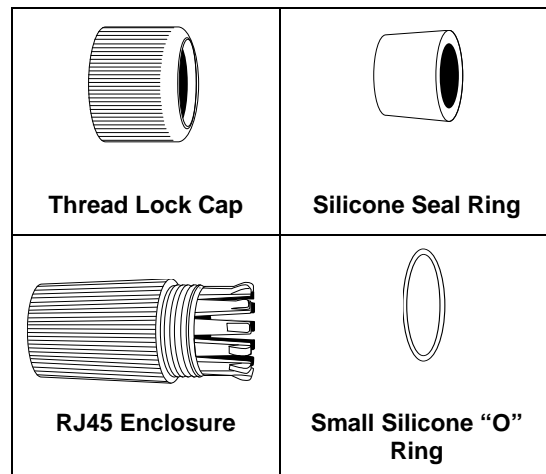

To Install the weather resistant cable connector, follow these steps:

1. Slide all pieces of the waterproof cable connector over the cable plug in this order:
 - Thread Lock Cap
 - Flexible silicone seal ring. You will need to stretch the silicone seal over the RJ-45 plug.

TIP: Insert the flexible silicone seal ring onto the tip of a pair of needle nose pliers and stretch the seal over the RJ45 plug

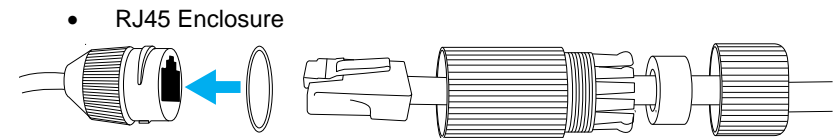

2. Stretch the small silicone "O" ring onto the camera dongle
3. Connect the camera cable to the plug on the dongle. Screw the RJ45 Enclosure into the dongle.
4. Insert the flexible silicone seal into the "crown" section of the large plastic ring
5. Screw the small plastic ring into the large plastic ring

TIP: To remove the RJ45 enclosure from the camera cable, tape down the locking tab on the RJ45 plug with electrical or office tape.

CAUTION: Do not attempt to disconnect the camera connection without loosening the smaller thread lock cap. Do not force. Forcing the assembly will break the camera dongle and will void camera warranty.

TWO: CONNECTING

BENCH TEST

AvertX recommends that you perform a bench test of your camera before installation. This will confirm that your camera is functioning correctly and familiarize yourself with the functions before it is installed and possibly out of reach.

To bench test your camera, attach the camera network connector to your recorder and test whether or not the camera is functioning correctly. Once the camera is connected to the recorder, test all functions (especially Auto Focus, Zoom, IR Night Vision) to ensure proper operation.

If the camera will not connect or is not functioning correctly, do not install and contact AvertX Support.

AvertX Camera Finder

The Camera Finder application is available to download at avertx.com.

Finding IP Cameras

1. Open the folder where you downloaded Camera Finder.
2. Click **Camera Finder**.
3. Click **Device Search** on the **Device Search** window.

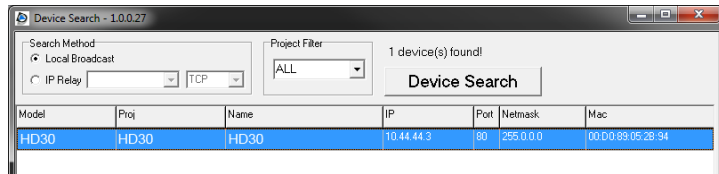

4. If a **Windows Security Alert** window opens, click **Unblock** to allow the IP utility to access your network.
5. Click **Device Search** again to find all connected IP devices.

Tip The default IP address of your IP camera is 192.168.0.250

35217AB

Note If you cannot connect to the camera you may need to change the camera's IP address to match your network settings.

Accessing the Camera

You can view live video and access the camera configuration by accessing the camera in an internet browser.

1. Right-click the desired network device and select **Browse**.
2. Type the default username and password in the login window to access the video server using your internet browser.

Changing the IP Address

If you are not directly connecting to an AvertX HDIP recorder, you must manually change the IP address. Change the IP address to a number in the same subnet as your existing network or to the recommended network settings for your network.

1. Right-click the desired network device and then click **Network Setup**.
2. Select the **Static IP** option.
3. Enter the new IP Address, Gateway, Netmask, and DNS for camera.

THREE: SETUP AND CONFIGURATION

INSTALLING THE CAMERA

Note: Before installing this camera, please refer to the Quick Start Guide included in the camera box.

The camera can be installed directly onto the wall or ceiling. Be sure that the structure is strong enough to support the camera.

Ceiling and Wall Installation

CAUTION: Using other screws or modifying the camera may allow water intrusion and void the warranty.

DO NOT DRILL HOLES OR ATTEMPT TO ENLARGE THE MOUNTING HOLES IN THE BASE OF THE CAMERA.

Dome cameras are ideal for installation on a ceiling or soffit location. If you are installing the camera on a wall without a bracket, see *Consideration for Wall Installations*.

1. If mounting on a concrete surface, use the included nylon anchors for mounting and the provided screws. Using the mounting template, drill a ¼" hole with a masonry bit and insert the nylon anchors. **Do not use concrete screws or other screws as they may damage the camera base, allowing water to potentially enter the camera and void your warranty.**
2. If mounting the camera onto **dry wall, plaster board, sheet rock** or similar surfaces, drill a ¼" hole for the nylon anchors included in the hardware packet and **use only the screws provided.**
3. If mounting the camera onto a **wood, OSB, particle board or metal** surface, pre-drill a 1/16" pilot hole and **use only the screws provided.**

4. If mounting the camera onto other surfaces such as **fiber glass, fiber concrete siding**, etc., use the appropriate anchor suitable for the density and thickness of the surface and **only the screws provided.**
5. Remove the camera dome cover by removing dome screws and lifting.
6. Use the included mounting template to pre-drill holes for the mounting screws and, if passing the cable through the ceiling or wall, drill a ¾" hole for the camera cable connector.
7. Connect an Ethernet cable to the dongle on the camera.
 - Protect the network cable connection from water damage by running the cord inside a wall or ceiling, or through conduit
 - For outdoor installations, seal any holes in the wall or ceiling with silicone caulk to protect against water intrusion.
8. Affix the base of the camera to the wall with the included self-tapping screws and wall anchors. Do not over tighten the mounting screws. Over tightening the screw could compromise the seal.
9. Loosen adjustment screw and adjust the camera to the desired angle.
10. Replace the dome cover. For proper dome alignment and seal, alternate tightening screws Do not over tighten.

Tilt and Rotation Adjustment

The HD320 has a 3-axis gimbal for maximum installation adjustment. To adjust tilt angle of lens, loosen the tilt adjustment lock screw with a Phillips screwdriver then move the tilt assembly to the desired position within the range of motion. Re-tighten screw carefully.

Note The will only tilt in one direction. If you are having trouble tilting the camera lens, do not force it. Try removing the shroud to see which direction the lens will tilt.

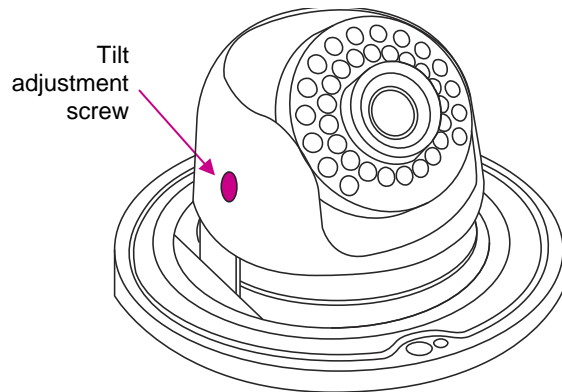

The lens will tilt 88° and rotate 355°. The lens will also rotate another 355°. To adjust angle, hold the lens carrier assembly. Do not hold lens or IR board when adjusting lens.

CAUTION: Do not hold IR board when tilting the lens. Lens will only tilt 88°. Do not force. Forcing the assembly will break the camera and will void camera warranty.

Consideration for Wall Installations

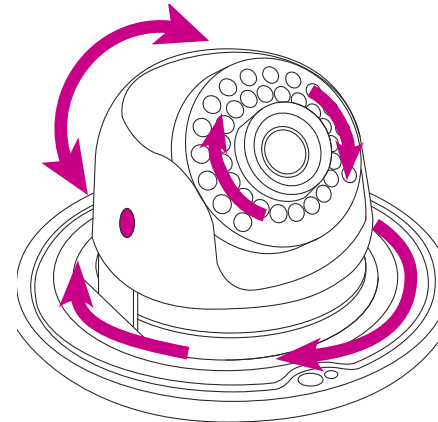

When mounting on a wall, and you choose to turn the camera to point parallel to the wall surface, you will need to rotate the camera lens for proper image orientation. The IR lights should be centered directly above the lens and level to the horizon for proper image orientation.

For optimal mounting flexibility on a wall, we recommend a mounting bracket. Wall mounts are available for purchase at avertx.com.

Note If the video image is upside down after installation, you can flip the image 180°. For instructions to rotate the video, see *Video Rotation* in this manual or find them at avertx.com/support.

Considerations for Infrared (IR) Lights

Environmental factors can limit the performance of night vision using IR illuminator lights. Infrared light behaves the same as visible light and will reflect off of bright or shiny objects and overexpose the image. The camera will adjust to properly expose the bright areas of the image, which may leave the dark areas obscured.

For best IR Night Vision performance:

Be aware of surfaces that can cause IR light to reflect back into the camera.

- Reflective (shiny) or light colored surfaces and objects close to the camera can reflect IR light back into the camera.
 - Remove the reflective (shiny) or light colored surfaces and objects or reposition the camera away from these objects.
- Mounting the camera directly to light colored or shiny soffits (white aluminum, for example) can reflect IR light back into the camera.
 - Reposition the lens so the IR lights aren't pointed at the soffit.
 - Cover the reflecting surfaces with non-reflective surface (non-reflective tape, dark paint)
 - Mount the camera on a nearby wall using a mounting bracket.

Screw the dome down completely

- The foam rubber ring around the lens prevents IR light from reflecting. It needs to completely seal against the inside of the dome. When properly sealed against the dome, the ring will appear darker.
- If surface mounting the cable, remove the cable knockout on the side of the dome cover. Failure to remove can prevent a complete seal.

Keep the dome clean

- See *Cleaning the Dome* for instructions to clean the dome

Note: Do not use solvents, paper towels, newspaper, or other rough materials to clean the dome. This can scratch the dome and cause IR distortion

MicroSD Card

Your camera includes a microSD card slot, which can be used for emergency video backup. The microSD card is not included. You must remove the cover of the camera to access the microSD card slot.

For more information, please consult the [Memory Card Storage](#) section in this manual.

Focusing the Camera Lens

The HD320 is pre-focused at the factory and cannot be adjusted by the end user. If your camera is out of focus, contact AvertX Support.

Cleaning the Dome

The dome of the HD320 is made of hardened polycarbonate. It is extremely durable, but can be damaged if cleaned improperly.

To clean the dome:

- To clean dust or loose dirt, use compressed air.
- To clean smudges or stuck on dirt, use warm water with a few drops of dish soap (Dawn, Palmolive, etc) and a clean microfiber cloth.

CAUTION: The following products can damage the dome and cause IR distortion and a reduction in clarity.

Do not use:

- Ammonia, alcohol, or other solvents
- Paper towels, newspaper, or other rough materials

CONNECTING TO THE CAMERA

Connecting in a Web Browser

1. Type the IP address of the camera in a web browser.
or
Use the Camera Finder software and locate the camera on the IP Finder list, then double-click the camera to open the Viewer software in your web browser.
2. Log in to the camera with the appropriate User Name and Password.

Default Username and Password

The username and password are case sensitive. It is strongly recommended that the password be changed after the initial setup to prevent unauthorized access.

Username – **admin**

Password – **1234**

Administrator/User Privileges

The Administrator account has the authority to configure the IP camera and authorize users' access to the camera. The User accounts have access to the camera with limited authority.

Connecting a Stream

AvertX IP cameras are optimized for use with AvertX HDIP recorders, but you can also connect to your AvertX IP cameras using third party software like VLC media player (<http://www.videolan.org>).

To connect the camera you may need to provide the stream URL. All AvertX IP cameras are capable of delivering two RTSP streams, as well as streaming MJPEG over HTTP. The stream URLs are listed below:

rtsp://<ipaddress>:<rtspport>/media/video1 - stream 1

rtsp://<ipaddress>:<rtspport>/media/video2 - stream 2

VLC will ask for the user name and password for your AvertX camera, use the following administrative credentials:

Username: admin

Password: 1234

PREPARATION

After you have completed the installation in accordance with the quick guide, connect the camera to power to start it. After the camera is started, you can access the camera from a PC client installed with a web browser or the video management software.

Check before login

- The camera is operating correctly.
- The network connection between the PC and the camera is normal.

Add the IP address as a trusted site

Note: The IP address 192.168.0.250 in this example is the default IP address. Please replace it with the actual address of your camera if it has been changed.

LOGGING INTO THE WEB INTERFACE

The default static IP address of the camera is 192.168.0.250, and the default subnet mask is 255.255.255.0. DHCP is turned on by default. If a DHCP server is used in the network, the IP address of your camera may be assigned dynamically, and you need to use the correct IP address to log in. Use the video management software to view the dynamic IP address of your camera.

The following takes IE as an example to describe the login procedure.

- Browse to the login page by entering the correct IP address of your camera in the address bar.
- If you log in for the first time, follow system prompts and install the ActiveX. You need to close your browser to complete the installation.

Note: To manually load the ActiveX, type `http://IP address/ActiveX/Setup.exe` in the address bar and press Enter.

- The default password is used for your first login. To ensure account security, please change the password after your first login. You are recommended to set a strong password (no less than eight characters).
- The camera protects itself from illegal access by limiting the number of failed login attempts. If login fails six times consecutively, the camera locks automatically for ten minutes.
- Enter the username and password, and then click **Login**. For the first login, use the default username: **admin** and password **1234**.
- If you log in with **Live View** selected, live video will be displayed when you are logged in. Otherwise, you need to start live video manually in the live view window.
- If you log in with **Save Password** selected, you do not need to enter the password each time when you log in. To ensure security, you are not advised to select **Save Password**.

- To clear the **Username** and **Password** text boxes and the **Save Password** check box, click **Reset**.

INTRODUCTION TO THE WEB INTERFACE

By default the live view window is displayed when you are logged in to the Web interface. The following shows an example.

INITIAL CONFIGURATION

After you log in to the device, please perform the following initial configuration.

Item	Description
1. Set the TCP/IP address for the device.	Reconfigure the device IP and network parameters based on the actual networking.
2. Log out and log in again to the Web using the new IP address.	-
3. Set the system time.	Set the system time based on the actual situation.
4.(Optional) Setting the servers.	Set the management server based on the actual networking.
5. Set OSD.	Set the information displayed on the screen as needed, for example, time.
6. (Optional) Manage users.	Change the default password and add common users as needed.

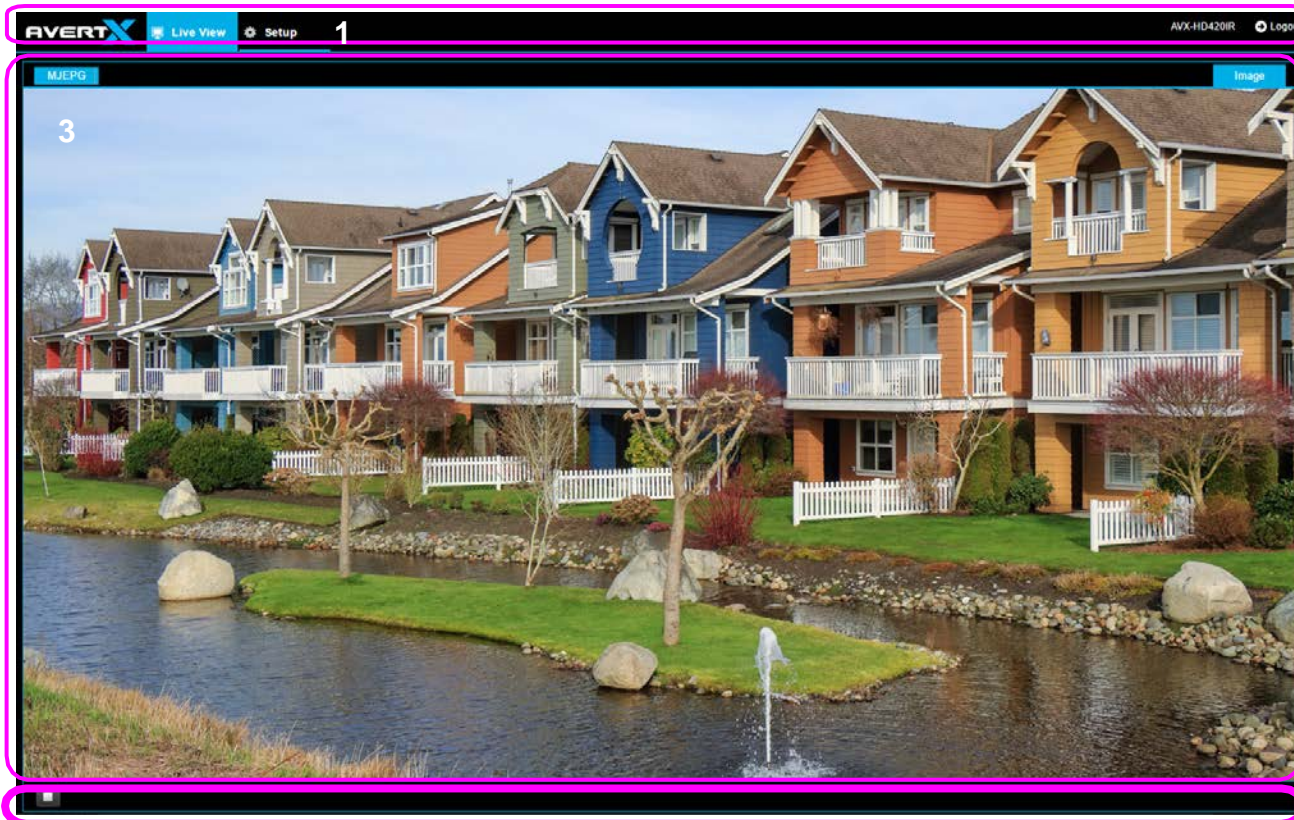

You can watch the live video after finishing the initial configuration. Please configure other parameters as needed.

No.	Description
1	Menu
2	Live view window
3	Live view toolbar

- The parameters that are grayed out cannot be modified. For the actual settings, see the Web interface.

- It is recommended that you change the password when you are logged in the first time. For details about how to change a password, see [Security](#).

FOUR: CONFIGURING SETTINGS

NETWORK CONFIGURATION

TCP/IP

Modify communication settings such as the IP address for the camera so that the camera can communicate with other devices.

The screenshot shows the camera's configuration web interface. On the left is a navigation menu with categories: Common, Network, Video, Image, Events, Storage, Security, and System. The 'Network' category is expanded to show 'TCP/IP' settings. The main content area is titled 'TCP/IP' and contains the following fields:

- IPv4:** DHCP/Static IP is set to 'DHCP'.
- IPv6:** IPv6 Mode is set to 'Manual'. IPv6 Address, Prefix Length (set to 64), and Default Gateway are empty.
- DNS:** Preferred DNS Server is 8.8.8.8, and Alternate DNS Server is 8.8.4.4.
- MTU:** 1500
- Port Type:** FE Port
- Operating Mode:** Auto-negotiation

A 'Save' button is located at the bottom of the configuration area.

Note: After you have changed the IP address, you need to use the new IP address to log in.

- The configurations of DNS (Domain Name System) server are applicable when the device is accessed by domain name.

IPv4

DHCP

The Dynamic Host Configuration Protocol (DHCP) is enabled by default when the camera is delivered. If a DHCP server is deployed in the network, the camera can automatically obtain an IP address from the DHCP server.

To manually configure DHCP, follow the steps below:

1. Click Setup > Network > TCP/IP.
2. Select **DHCP** from the **IP Obtain Mode** drop-down list.
3. Click **Save**.

Static Address

1. Click Setup > Network > TCP/IP.
2. Select **Static IP** from the **IP Obtain Mode** drop-down list.
3. Enter the IP address, subnet mask, and default gateway address. Make sure that the IP address of the camera is unique in the network.
4. Click **Save**.

If a gatekeeper or firewall is used in the network, Universal Network Passport (UNP) can be used to interconnect the network, and the UNP server will assign an IP address to the connected cameras.

1. Select **Enable** for UNP Service.
2. In the **UNP Server IP** text box, enter an IP address for the UNP server. Select **Yes** to enable authentication, and then set the username and password for UNP authentication.
3. Click **Save**.

PPPoE

If the camera is connected to the network through Point to Point Over Ethernet (PPPoE), you need to select PPPoE as the IP obtainment mode.

1. Click Setup > Network > TCP/IP.

2. Select PPPoE from the IP Obtain Mode drop-down list.
3. Enter the username and password provided by your internet Service Provider (ISP).
4. Click Save.

Port

Port

HTTP Port 80

HTTPS Port 443

RTSP Port 554

Note: Modifying the RTSP or server port number will cause the device to restart.

Save

1. Click Setup > Network > Port.
2. Configure relevant port numbers.
3. Click **Save**.

Note: If the entered HTTP port number has been occupied, a prompt message will be displayed as **Port conflicts. Please try again.** 23, 81, 82, 85, 3260 and 49152 are occupied by default. And other occupied ports will be detected automatically.

DDNS

DDNS (Dynamic Domain Name Service) is a service that allows a connection to an IP address using a hostname (URL) address instead of a numeric IP address. Most Internet Service Providers use Dynamic IP Addressing that frequently changes the public IP address of your internet connection; this means that when connecting to the camera over the internet, you need to know if your IP address has changed. DDNS automatically redirects traffic to your current IP address when using the hostname address.

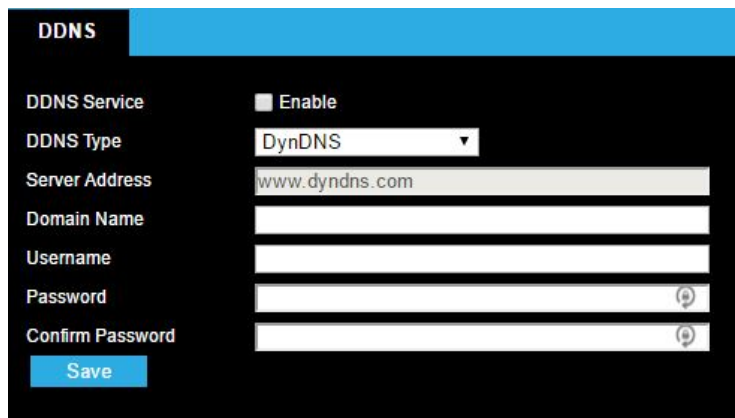

1. Click Setup > Network > DDNS.
2. Enable DDNS Service.
3. Enter DDNS info provided by your DDNS provider.
4. Click **Save**.

FTP

After the configuration of FTP, you will be able to upload snapshots from network cameras to a specified FTP server.

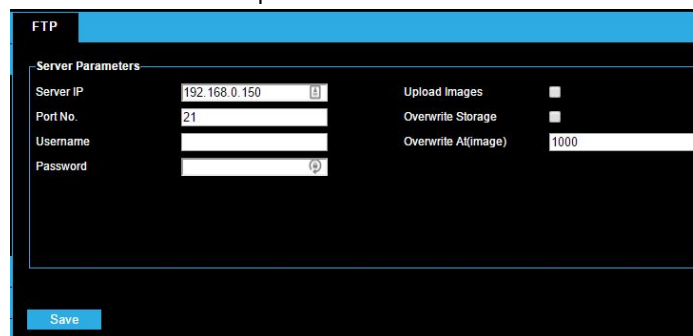

1. Click Setup > Network > FTP.
2. Configure the IP address, port number of the FTP server, the username and password of the upload account, enable **Upload Images** and **Overwrite Storage**, and then set the overwrite image threshold.
3. Click **Save**.

E-Mail

After the configuration of E-mail, when alarms are triggered, you will be able to send messages to the specified E-mail address.

The camera can send an e-mail via Simple Mail Transfer Protocol (SMTP) when a variety of events occur. SMTP is a protocol for sending e-mail messages between servers. SMTP is a relatively simple, text-based protocol, where one or more recipients of a message are specified and the message text is transferred. Consult your email provider to get your SMTP server information.

Three accounts can be configured. Each set includes, Account Name, Password and E-mail Address settings. For SMTP server, contact your network service provider for more specific information.

1. Click Setup > Network > E-mail.
2. Configure relevant parameters of the sender and the recipient. The following table describes some major parameters.

Parameter	Description
Attach Image	When enabled, the e-mail will contain 3 instant snapshots as attachment according to the Capture Interval.

3. Click **Save**.

Port Mapping

Port Type	External Port	External IP	Status
HTTP	50080	0.0.0.0	Inactive
RTSP	50554	0.0.0.0	Inactive
Server	50081	0.0.0.0	Inactive

1. Click Setup > Network > Port Mapping.
2. Enable **Port Mapping** and select mapping type. If **Manual** is selected, then external ports must be configured (external IP is obtained automatically by the camera). If the configured port is occupied, then the **Status** will show Inactive.
3. Click **Save**.

VIDEO CONFIGURATION

Video Configuration

You can set video parameters that your camera. You may also enable sub-stream.

After enabling the sub, modify the parameters as required. The parameters for the sub and third stream have the same meanings as that for the main stream.

1. Click Setup > Video > Video.
2. Modify the settings as required. The following table describes some major parameters.

Parameter	Description
Bitrate Type	CBR: Constant Bit Rate, which means that the camera transmits data at a constant data rate. VBR: Variable Bit Rate, which means that the camera adjusts the bit rate dynamically according to image quality.
Frame Rate	Frame rate for encoding images. Unit: FPS (frame per second). Note: To ensure image quality the frame rate should not be greater than the reciprocal of shutter speed.
Image Quality	When Encoding Mode is VBR, you can move the slider to adjust quality level for images. Moving the slider toward Bit Rate decreases the bit rate and may affect image quality. Moving the slider toward Quality
Smoothing	Set the extent of smoothing. Choosing Clear means disabling Smoothing. Moving the slider toward Smooth increases the level of smoothing but will affect image quality. Note: In a poor network environment, you can enable smoothing to get more fluent video.

3. Click **Save**.

Configuring Capture

With the function of capture configured, when an alarm is triggered, the camera will automatically upload the captured snapshots to the FTP server or send snapshots the specified email address.





1. Click Setup > Video > Capture.
2. Configure relevant parameters.
3. Click **Save**.







IMAGE CONFIGURATION







Image Enhancement

Note: You may move the sliders to adjust settings or enter values in the text boxes directly. Clicking **Default** will restore all the default image settings.

1. Click Setup > Image > Image and then click Image Enhancement.
2. Use the sliders to change the settings. You may also enter values directly. The following table describes some major parameters.

Item	Description
Brightness	<p>Set the degree of brightness of images.</p> <div style="display: flex; justify-content: space-around;">   </div> <p style="display: flex; justify-content: space-around;"> Low brightness High brightness </p>
Saturation	<p>Set the intensity of color in the image.</p> <div style="display: flex; justify-content: space-around;">   </div> <p style="display: flex; justify-content: space-around;"> Low saturation High saturation </p>

Contrast	<p>Set the degree of difference between the blackest pixel and the whitest pixel.</p> <div style="display: flex; justify-content: space-around;">   </div> <p style="display: flex; justify-content: space-around;"> Low contrast High contrast </p>
Hue	<p>Overall tendency of colors in an image.</p> <div style="display: flex; justify-content: space-around;">   </div> <p style="display: flex; justify-content: space-around;"> Normal hue Other hue </p>
Sharpness	<p>Contrast of boundaries of objects in an image.</p> <div style="display: flex; justify-content: space-around;">   </div> <p style="display: flex; justify-content: space-around;"> Low sharpness High sharpness </p>
2D Noise Reduction	<p>Reduce the noise of images. The function may cause image blurring.</p>

3D Noise Reduction	Reduce the noise of images. The function may cause motion blur (or ghosting in some applications).
Image Rotation	<p data-bbox="401 323 638 347">Rotation of the image.</p> <div data-bbox="401 363 873 1089">       </div> <p data-bbox="401 521 478 545">Normal</p> <p data-bbox="401 703 558 727">Flip Horizontal</p> <p data-bbox="401 1065 554 1089">90° Clockwise</p> <p data-bbox="688 521 814 545">Flip Vertical</p> <p data-bbox="688 703 741 727">180°</p> <p data-bbox="594 1065 789 1089">90° Anti-clockwise</p>

- To restore default settings in this area, click **Default**.

Exposure

The default settings are used for common scenes. Keep the default settings unless a particular scene is required.

- Click **Setup > Image > Image** and then click **Exposure**.



- Set the parameters as required. The following table describes some major parameters.

Parameter	Description
Exposure Mode	Select the correct exposure mode to achieve the desired exposure effect.
Shutter (s)	Shutter is used to control the light that comes into the lens. A fast shutter speed is ideal for scenes in quick motion. A slow shutter speed is ideal for scenes that change slowly. Note: You can set a shutter speed when Exposure Mode is set to Manual or Shutter Priority. If Slow Shutter is set to Off, the reciprocal of the shutter speed must be greater than the frame rate.
Gain (dB)	Control image signals so that the camera outputs standard video signals according to the light condition. Note: You can set this parameter only when Exposure Mode is set to Manual or Gain Priority.
Slow Shutter	Improves image brightness in low light conditions. Note: You can set this parameter only when Exposure Mode is not set to Shutter Priority and when Image Stabilizer is disabled.
Slowest Shutter	Set the slowest shutter speed that the camera can use during exposure. Note: You can set this parameter only when Slow Shutter is set to On.
Compensation	Adjust the compensation value as required to achieve the desired effects. Note: You can set this parameter only when Exposure Mode is not set to Manual.

Metering Control	Set the way the camera measures the intensity of light. Center-Weighted Average Metering: Measure light mainly in the central part of images. Evaluative Metering: Measure light in the customized area of images. Note: You can set this parameter only when Exposure Mode is not set to Manual.
Day/Night Mode	Automatic: The camera outputs the optimum images according to the light condition. In this mode, the camera can switch between night mode and day mode automatically. Night: The camera provides high-quality black and white images using the existing light Day: The camera provides high-quality color images using the existing light. Input Boolean: The camera switches between day mode and night mode based on the alarm input.
Day/Night Sensitivity	Light threshold for switching between day mode and night mode. A higher sensitivity means that the camera is more sensitive to the change of light and becomes more easily to switch between day mode and night mode. Note: You can set this parameter only when Day/Night Mode is set to Automatic.
Day/Night Switching(s)	Set the length of time before the camera switches between day mode and night mode after the conditions for switching are met. Note: You can set this parameter only when Day/Night Mode is set to Automatic.
WDR	Enable WDR to distinguish the bright and dark areas in the same image. Note: You can set this parameter only when Exposure Mode is set to Automatic, Indoor 50Hz, Indoor 60Hz and when Image Stabilizer and Defog is disabled.

WDR Level	<p>After enabling the WDR function, you can improve the image by adjusting the WDR level.</p> <p>Note: Use level 7 or higher when there is a high contrast between the bright and dark areas of the scene. In the case of low contrast, it is recommended to disable WDR or use level 1-6.</p>
-----------	---

- To restore the default settings, click **Default**.

Smart Illumination

- Click Setup > Image > Image and then click Smart Illumination.
- Select the corresponding lightning type and then configure other parameters.

Parameter	Description
Control Mode	<p>Global Mode: The camera adjusts IR illumination and exposure to achieve balanced image effects. Some areas might be overexposed if you select this option. This option is recommended if monitored range and image brightness are your first priority.</p>
	<p>Overexposure Restrain: The camera adjusts IR illumination and exposure to avoid regional overexposure. Some areas might be dark if you select this option. This option is recommended if clarity of the central part of the image and overexposure control are your first priority.</p>
	<p>Manual: This mode allows you to manually control the intensity of IR illumination.</p>
Illumination Level	<p>Set the intensity level of the IR light. The greater the value, the higher the intensity. 0 means that the IR light is turned off.</p> <p>Note: You can set this parameter only when Control Mode is set to Manual.</p>

- Select the correct IR control mode and set the parameters. The following table describes some major parameters.
- To restore the default settings, click **Default**.

White Balance

White balance is the process of offsetting unnatural color cast in images under different color temperatures so as to output images that best suit human eyes.

- Click Setup > Image > Image and then click White Balance.
- Select a white balance mode as required. The following table describes some major parameters.

	Description
White Balance	<p>Adjust the red or blue offset of the image:</p> <p>Note: The camera adjusts the red and blue offset automatically according to the light condition (the color tends to be blue).</p> <p>Fine Tune: Allow you to adjust the red and blue offset manually.</p> <p>Sodium Lamp: The camera adjusts red and blue offset automatically according to the light condition (the color tends to be red).</p> <p>Outdoor: It is recommended for the outdoor scenes with a wide range of the color temperature variation</p> <p>Locked: Lock the current color temperature settings without adjustment.</p>
Red Offset	<p>Adjust the red offset manually.</p> <p>Note: You can set this parameter only when White Balance is set to Fine Tune.</p>
Blue Offset	<p>Adjust the blue offset manually.</p> <p>Note: You can set this parameter only when White Balance is set to Fine Tune.</p>

- To restore the default settings, click **Default**.

Defog

Use the defog function to adjust the clarity of images captured in fog or haze conditions.

1. Click **Setup > Image > Image** and then click **Advanced**.

Note: This function can be configured only when WDR is disabled.

2. Enable the defog function and then select a level for the scene. Level 5 achieves the maximum defog effects, and level 1 achieves the minimum.
3. To restore the default settings, click **Default**.

OSD Settings

On Screen Display (OSD) is the text displayed on the screen with video images and may include time and other customized contents.

1. Click Setup > Image > OSD.

Enable	No.	Overlay OSD Content	X-Axis	Y-Axis	Status
<input type="checkbox"/>	1		2	3	
<input type="checkbox"/>	2		85	90	
<input type="checkbox"/>	3		2	75	
<input type="checkbox"/>	4		0	0	
<input type="checkbox"/>	5		0	0	
<input type="checkbox"/>	6		0	0	
<input type="checkbox"/>	7		0	0	
<input type="checkbox"/>	8		0	0	

Display Style	
Effect	Background
Font Size	Medium
Font Color	#0000-1
Min. Margin	None
Date Format	dd/MM/yyyy
Time Format	HH.mm.ss

dd=Day, dddd=Day of the week, M=Month, y=Year
h/H=12/24 Hour, tt=A.M. or P.M., mm=Minute, ss=Second

2. Select the check box, the content of the OSD and then set the position to display it.
3. Position: Click the desired box in the **Live View** area. After the cursor shape is changed, click and hold the button to move the box to the desired position. To set the position precisely, use the X and Y coordinates under **Overlay Area**.
4. Overlay OSD Content: The drop-down list provides **Time**, **Preset** and **Serial Info**. You may also select **Custom** and enter the content you want.
5. After you have set the position and OSD content, the  symbol appears in the **Status** column, which means that the OSD is set successfully. You may set multiple lines of contents for each area and use and to adjust the sequence of display.
6. After you have completed the settings, a message appears to indicate the successful settings.

You may right-click in the preview window and then choose to view in full screen mode or at an aspect ratio. You may also double-click the preview window to enter or exit full screen mode.

To cancel OSD for an area, clear the OSD content in the **Overlay OSD Content** column or select **None** in the Position column.

The following shows an example time OSD.



Privacy Mask

On certain occasions, you may need to set a mask area on the camera image to protect privacy, for example, the keyboard of an ATM machine. When PTZ changes its position or zooms, the Privacy Mask will be adjusted accordingly to protect the area all along.

1. Click Setup > Image > Privacy Mask.

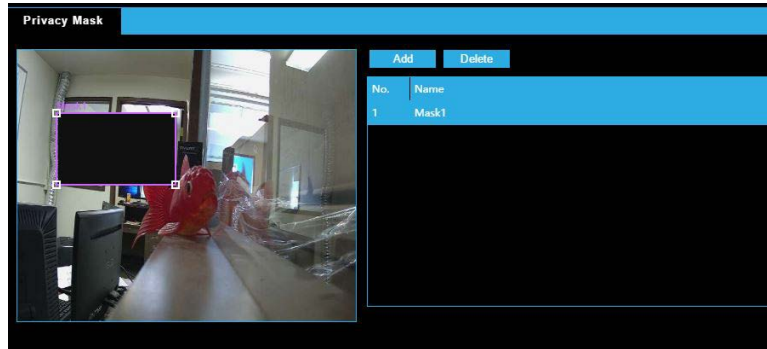

2. Click **Add** to add a privacy mask, and click **Delete** to delete a mask.
3. To mask a position: Click the box (with **Mask** displayed on it) to activate the mask. After the cursor shape has changed, drag the box to the intended position.
4. To mask an area: Use the mouse to draw a box on the area you want to mask.

When privacy mask is configured, the intended area is blocked.

ALARM CONFIGURATION

You can schedule alarm reporting and set actions that can be triggered by other devices so that alarms and the triggered actions can be handled in time.

Alarm reporting can be scheduled for motion detection alarm and tampering detection alarm.

Configuring Motion Detection Alarm

Motion Detection

Motion detection detects the object motion in a specified rectangular area during a period. You need to set a detection area, sensitivity of detection, object size, and history for the camera to decide whether to report a motion detection alarm when it detects motion.

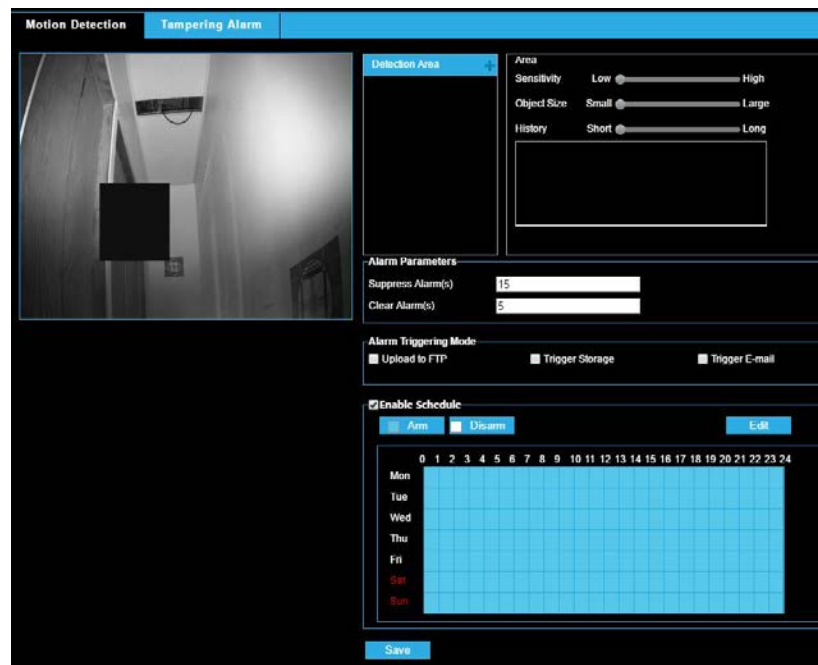

1. Click Setup > Events > Common Alarm > Motion Detection.

2. In the **Detection Area** area, click to add a new detection area. To delete a detection area, click .
3. Click and drag the mouse to set a detection area.
4. Set the detection sensitivity, object size, and history for the camera to decide whether to report a motion detection alarm.
5. Moving the slider to the right increases detection sensitivity. When the extent of motion within the detection area exceeds the set object size, and if the duration of motion exceeds the set duration, the camera reports an alarm.
6. Motion detection results are shown in real time. The red lines represent the raised motion detection alarms. The longer a line, the greater the extent of motion. The denser the lines, the greater the frequency of motion.
7. Set the alarm parameters.
8. Set actions to be triggered by motion detection alarm and the plan.

The following table describes the alarm parameters and the alarm-triggered actions and how to set a schedule.

Item	Description
Suppress Alarm(s):	After an alarm is triggered, the same alarm will not be reported within the settime.
Clear Alarm(s):	After an alarm is triggered, If the same alarm is not triggered within the set time, the alarm will be cleared and the same alarm can be reported again. If the same alarm is triggered within the set time, the alarm will not be cleared until the suppress alarm time expires. Then the same alarm can be reported again.
Upload to FTP	With Upload to FTP selected, the camera will automatically upload snapshots to the specified FTP server when an alarm is triggered. Note: Make sure you have completed FTP and Configuring Capture before using this function.

Trigger E-mail	<p>With Trigger E-mail selected, the camera will automatically send snapshots to the specified E-mail address when an alarm is triggered.</p> <p>Note: Make sure you have completed E-Mail and Configuring Capture before using this function.</p>
Trigger Storage	<p>With Trigger Storage enabled, the camera automatically starts recording after an alarm is triggered.</p> <p>Note: Make sure you have completed the post-recording time settings before using this function.</p>
Enable Schedule	<p>Select the check box and set the start and end times during which motion detection alarm is effective. You can directly drag the mouse to draw a plan and click Edit to edit time periods in the table. The time periods cannot overlap. The camera reports alarms during the specified period(s) only.</p> <p>You can select from Monday to Sunday and set four periods for each day.</p>

9. Click **Save**.

Configuring Tampering Alarm

Configure tampering alarm so that the camera reports a tampering alarm when the lens is blocked for a certain length of time.

Motion Detection Tampering Alarm

Tampering Alarm Enable

Sensitivity 23

Duration(ms)/Ratio(s)

Alarm Triggering Mode

Trigger Storage

Enable Schedule

	0	1	2	3	4	5	6	7	8	9	10	11	12	13	14	15	16	17	18	19	20	21	22	23	24
Mon																									
Tue																									
Wed																									
Thu																									
Fri																									
Sat																									
Sun																									

1. Click Setup > Events > Tampering Alarm.
2. Select Enable for Tampering Alarm.
3. Set detection sensitivity and duration for the camera to decide whether to report a tampering alarm. The camera can be more sensitive to the blocking even it only blocks the camera lens slightly from a farther location when sensitivity is set to high. The camera reports an alarm when the lens is blocked for a specified length of time.

Tampering alarm is effective to the whole screen. To disable tampering alarm, clear the **Tampering Alarm** check box.

4. Set actions to be triggered by tampering alarms and the plan. For detailed steps, see the descriptions of alarm-triggered actions in [Configuring Motion Detection Alarm](#).
5. Click **Save**.

MEMORY CARD STORAGE

Your camera includes a microSD card slot, which can be used for emergency video backup. The microSD card is not included. You must remove the cover of the camera to access the microSD card slot.

You can use any class MicroSDHC card up to 128GB. This will hold approximately 15 hours of video at 15 FPS 4MP resolution. It saves the video files on the SD card in a series of 500mb .ts files. You can access the recordings via any card reader that reads MicroSD cards or use the Recording Download utility in the camera software. We recommend you view the video backup files on VLC player, a free download.

Manual storage

The camera records live video repeatedly if manual storage is enabled.

1. Click Setup > Storage > Storage.

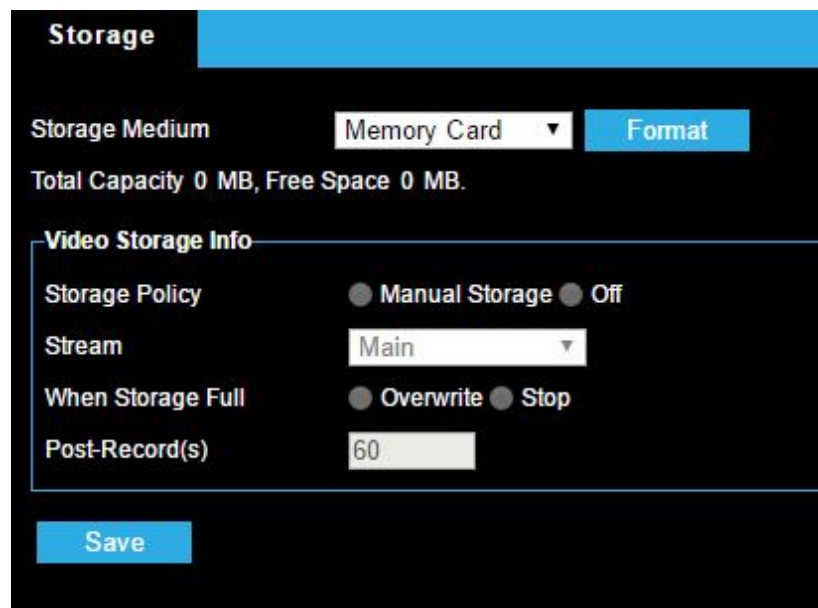

2. Enable memory card storage and modify the settings as required. The following table describes some major parameters.

Parameter	Description
Storage Medium	Storage resource type. Note: To format the memory card, disable the storage function for the card first. Then Click Format and then click OK to confirm the operation. The system will restart when the format is completed. Information about the total and free space is displayed.
When Storage Full	Overwrite: If there is no free space in the memory card, new data will overwrite the existing data repeatedly. Stop: If there is no free space in the memory card, new data will not be saved to the memory card.
Post-Record(s)	When an alarm is raised, the camera is triggered to record live video and continues recording for a set post-record time after the alarm is cleared.

3. Click Save.

DOWNLOADING RECORDED VIDEO FROM SD CARD

Note: The downloaded file will be in the .ts format. We recommend using VLC Player (a free download) to view the file.

Record Download

1. Click Setup > Storage > Record Download.



The screenshot shows a web interface titled "Recording Download". At the top, there is a search filter for "Recording Time" with two date pickers set to "2016-08-11" and a "Search" button. Below the search filter is a table with the following data:

No.	Start Time	End Time	Panel
1	2016-08-11 10:33:24	2016-08-11 10:48:05	Download
2	2016-08-11 10:48:07	2016-08-11 11:02:31	Download

2. Search for video within a specified period. The results will be shown in a list.
3. Select your video and click Download. The video will be downloaded to the Downloads folder on your computer from the memory card (local path can be changed in System Configuration).

SECURITY

User Management

There are two types of users in the system:

- Administrator: referred to as “admin” in this manual. The default name of the administrator is admin, which cannot be modified. Admin has full permission and can manage all users and devices. Only one admin user is allowed in the system.
- Common user: referred to as “user” in this manual. User only has permission to play live and recorded video. Up to 31 common users are allowed in the system.

You can add a user on the user management interface (under **Setup > System > Security > User**).

After the user is added successfully, you can change the password by entering the new password or delete the user by clearing the username.

Note: Only admin can change passwords. Changing the username or password for a user when the user is still logged in will force the user to log out. The user must use the new username or password to log in.

- Only admin can add and delete users. Deleting a user when the user is still logged in will force the user to log out. A deleted user cannot log in.

Setting Secure Data Transmission

HTTPS

HTTPS allows secure connections between the IP Camera and web browser that protects camera settings or Username/Password info from snooping.

To use HTTPS, you are required to install a self-signed certificate or a Authority (CA) -signed certificate. The HTTPS certificate can be obtained by either creating and sending a certificate request to a CA or creating a self-signed HTTPS certificate

The screenshot shows a configuration window titled "Port" with a dark background. It contains three input fields: "HTTP Port" with the value "80", "HTTPS Port" with the value "443", and "RTSP Port" with the value "554". Below these fields is a red-bordered box containing the text: "Note: Modifying the RTSP or server port number will cause the device to restart." At the bottom of the window is a blue "Save" button.

1. Click Setup > Network > Port.
2. Enter the port number in the **HTTPS Port** text box and then click **Save**.
3. Click Setup > System > Security.
4. Under **HTTPS**, select **Enable**. Uploading a custom SSL certificate is also supported to ensure security.
5. Click **Save**.

Next time you log in, enter the address in *https://IP:HTTPS port number* format, for example, <https://192.168.0.250:443>, to enter secure channel mode. If HTTPS uses a default port number, enter the address in <https://IP> directly.

APR Binding

This function can protect the camera from ARP attacks. When the camera visits an IP of another network segment via a gateway, it can communicate only with the MAC address binding to the gateway address in the same segment.

1. Click **Setup > System > Security > ARP Binding**.
2. Select the check box to enable the ARP binding function and set the MAC address.
3. Click **Save**.

Hide Vendor Information

You can set to hide the vendor information of the network camera on the Web interface.

1. Click **Setup > System > Security**.
2. Under Registration Info, select **Enable**.

Video Watermark

You can set the video watermark for the camera to encrypt the video and protect it from being deleted or modified.

1. Click **Setup > System > Security > Video Watermark**.
2. Select **Enable** and set the watermark content.
3. Click **Save**.

SYSTEM

Setting the System Time

You can use the following methods to adjust the system time of your device.

Manually Setting or Synchronizing the System Time

1. Click **Setup > Common > Time**, and then click the **Time** tab.
2. Select **Enable** for Client Time Synchronization.
3. Click **Save**.

Synchronizing with the NTP Server

1. Click **Setup > Common > Time**, and then click the **Time** tab.
2. Select **Enable** for **NTP**, and then enter the IP address of the NTP server and the camera's sync interval with the NTP server.
3. Click **Save**. The camera will periodically synchronize time with the NTP server.

Setting the DST

1. Click **Setup > Common > Time**, and then click the **DST** tab.
2. Select **Enable DST**, set the start time, end time, and DST bias.
3. Click **Save**.

Viewing Device Status

You can view the current status of your camera.

Basic Info	
Basic	
Product Model	AVX-HD820IR
Firmware Version	IPC_Q1201-B5016P01D1604C09
Hardware Version	A
Boot Version	V3.3
Product Bar Code	210235T25N3165000001
Network	10.1.0.226/255.255.0/10.1.0.254
Status	
Device Time	2016/8/11 8:42:37
Operation Time	1 Day(s) 1 Hour(s) 8 Minute(s)
Edge Storage	undefined
Refresh	

- Click Setup > Common > Basic Info.
- Click **Refresh** for the latest status information.
- View the device information.

Upgrading the Device

New versions of camera firmware is available periodically and can be found at <http://www.avertx.com/product-downloads/>.

Maintenance	
Firmware Upgrade	
Upgrade File	<input type="text"/> <input type="button" value="Browse..."/> <input type="button" value="Upgrade"/>
Device Restart	
<input type="button" value="Restart"/>	Restart the device.
Config Management	
<input type="button" value="Default"/>	<input type="checkbox"/> Do not keep current network and user settings and restore all settings to defaults.

Note: Make sure the software upgrade file is available before starting the software upgrade.

1. Click Setup > System > Maintenance.
2. Under **Firmware Upgrade**, click **Browse** and select the correct upgrade file.
3. (Optional) Select the check box to enable **Upgrade Boot Program**.
4. Click **Upgrade** and then confirm to start. The camera will restart automatically after the upgrade is completed.

Note: You must use the correct upgrade file for you camera. Otherwise, unexpected results may occur.

- The upgrade file is a ZIP file and must include all the necessary files.
- The boot program loads the operating system and then the system starts running. The upgrade boot program function is disabled by default, and only the camera will be upgraded to the latest version. If enabled, both the camera and the boot program are upgraded, and the operating system of the following new versions can be booted properly and the camera can be upgraded conveniently.

- Ensure that the power supply is normal during upgrade. The device will restart after the upgrade is completed.

4. To restore default configurations, click **Default** and then confirm the operation. The device will restart and restore the default configurations.

Restarting the System

1. Click Setup > System > Maintenance.
2. Under **Device Restart**, click **Restart**. The device will restart after you confirm the operation. You may also enable auto-restart by selecting **Enable Auto Restart** and setting a time for auto-start. The device will restart at the set time.

CAUTION! Perform this operation with caution because restarting the system interrupts the ongoing service.

Importing and Exporting System Configuration File

Export the current configurations of the camera and save them to the PC or an external storage medium. You can also quickly restore configurations by importing backup configurations stored on the PC or an external storage medium back to the camera.

CAUTION! After you perform the Default operation, all settings are restored to factory defaults, except the following: login password of the system administrator, network settings, and system time.

Make sure you import the correct configuration file for your camera. Otherwise, unexpected results may occur. The camera will restart when the configuration file is imported successfully.



1. Click Setup > System > Maintenance.
2. To import configurations that you have backed up, click **Browse** next to the **Import** button and select the configurations you want to import, and then click **Import**. The result will be displayed.
3. To export configurations, click **Browse** next to the **Export** button, select the destination folder, and then click **Export**.

FIVE: LIVE VIEW

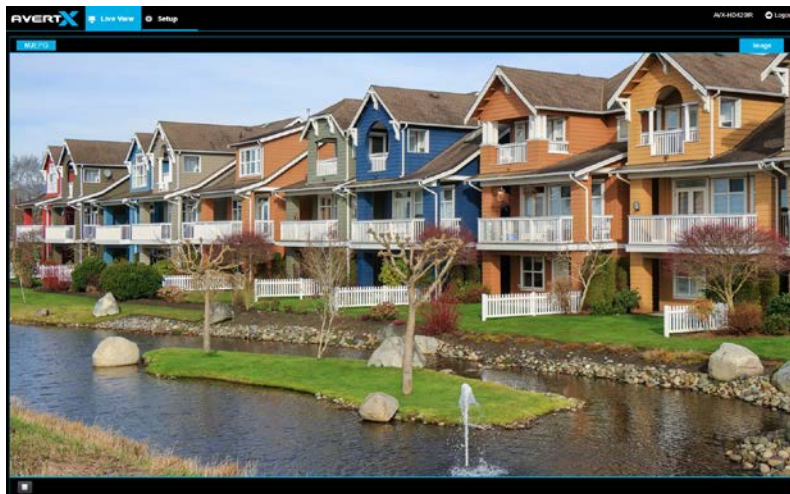
Live view means playing live video (real-time audio and video) received from a camera in a window through the Web interface.



LIVE VIEW TOOLBAR

Button	Description
	Display in full screen mode.
	Play/stop live video.

APPENDIX A

GLOSSARY

Acronym	Description
ARP	Address Resolution Protocol
CBR	Constant Bit Rate
DNS	Domain Name Service
DDNS	Dynamic Domain Name Service
DHCP	Dynamic Host Configuration Protocol
DST	Daylight Saving Time
FTP	File Transfer Protocol
GOP	Group Of Pictures
GUI	Graphical User Interface
HTTPS	Hyper Text Transfer Protocol over SSL
IE	Internet Explorer
IMOS	IP Multimedia Operation System
IP	Internet Protocol
IPC	IP Camera
MTU	Maximum Transmission Unit
NTP	Network Time Protocol

OSD	On Screen Display
PoE	Power over Ethernet
PPPoE	Point-to-Point Protocol over Ethernet
PTZ	Pan, Tilt, Zoom
ROI	Region of Interest
SMTP	Simple Mail Transfer Protocol
SSL	Secure Socket Layer
UNP	Universal Network Passport
USB	Universal Serial Bus
VBR	Variable Bit Rate
WDR	Wide Dynamic Range

APPENDIX B FAQ

What to do if no message prompts me to install ActiveX when I log in on a Windows 7 PC the first time

Answer: Follow these steps to turn off UAC and then log in again:

- Click the **Start** button, and then click **Control Panel**.
- In the search box, type uac, and then click **Change User Account Control Settings**.
- Move the slider to the **Never Notify** position, and then click **OK**.
- After UAC is turned off, log in again.

What to do if the installation of ActiveX failed

Answer: If the installation failed, add the IP address of the camera as a trusted site: open **Internet Option**

in IE, click the **Security** tab, click **Trusted sites**, and then click **Sites** to add the website.

If you use Windows 7, you need to save the **setup.exe** to your PC first, right-click the file, select **Run as administrator**, and then install it according to instructions.

What to do if live video fails when I log in for the first time

Answer: Close the firewall on your PC and then log in to the Web interface again.

APPENDIX C: SPECIFICATIONS

CAMERA SPECIFICATIONS

Model	HD320
Resolution	4MP (2592x1520)
Number of Video Streams	2 (High resolution stream for single camera view, low resolution stream for multiple camera view)
Frames Per Second	20 fps @ 4MP (2592 x 1520) or 30 fps @ 3MP (2048x1520)
Image Sensor	1 / 3" CMOS
Wide Dynamic Range	Spectrum Vision True WDR / HDR
Focal Length	3.6 mm Fixed
FOV	80°
Lens Adjustment	3-Axis
Iris Control	Auto Iris
Backlight Compensation	Yes
Auto Gain Control	Yes
Minimum Illumination	Color Mode: 0.02 Lux, B/W Mode: 0 Lux with IR on
Day / Night	True Day / Night with IR Cut Filter
IR LEDs	35 High Intensity IR LEDs
Max IR Range*	Up to 100 feet (30 m) from camera
Optimal IR Range*	Up to 60 feet (20 m) from camera
Auto White Balance Range	2700K ~ 7800K

Compression	H.264
MicroSD Backup Slot	Up to 128 GB
Input Voltage	PoE Only IEEE 802.3af Power over Ethernet 48vDC
ONVIF Compliance	Profile S**
IP Rating	IP66
Tamper/Vandal Resistant	IK10 Rated
Heater	Yes
Operating Temperature	-35° ~ 140°F (-37° ~ 60°C)
Cold Start Temperature	-35° F (-37° C)
Audio	No
Dimensions	Ø 4.28" x H 3.2" (108.5 x 81 mm)
Weight	1 lbs (450 g)
Mounting Hardware Included	Yes

Are any parts of this manual incomplete or unclear? Please let us know!
Contact us at support@avertx.com with your comments.

www.avertx.com

1-855-2AVERTX
© 2015 AvertX

All rights reserved. No part of this publication may be reproduced by any means without written permission from AvertX. The information in this publication is believed to be accurate in all respects. However, AvertX cannot assume responsibility for any consequences resulting from the use thereof. The information contained herein is subject to change without notice. Revisions or new editions to this publication may be issued to incorporate such changes.